

LEGEND	
	GREEN ROOF
	BIORETENTION
	PERMEABLE PAVEMENT

STORMWATER MANAGEMENT NARRATIVE:

THE PROJECT WILL BE UNDER THE 2013 STORMWATER MANAGEMENT REQUIREMENTS PER THE DEPARTMENT OF ENERGY AND ENVIRONMENT. THIS WILL BE A MAJOR LAND DISTURBING ACTIVITY, THEREFORE, THE SITE WILL RETAIN THE FIRST 1.2" OF RAINFALL. GREEN ROOF, PERMEABLE PAVEMENT AND BIORETENTION WILL BE USED TO MEET THE RETENTION AND DETENTION REQUIREMENTS.

STORMWATER MANAGEMENT NARRATIVE:
MAXIMUM EXTENT PRACTICABLE IN THE PROW

THE PUBLIC RIGHT OF WAY PORTION OF THIS PROJECT WILL BE UNDER THE 2013 STORMWATER MANAGEMENT REQUIREMENTS PER THE DEPARTMENT OF ENERGY AND ENVIRONMENT. THE SITE WILL MEET THE PUBLIC RIGHT OF WAY STORMWATER REQUIREMENTS TO THE MAXIMUM EXTENT PRACTICABLE.

"PUBLIC PARK AND ADJACENT PUBLIC SPACE TO BE DEVELOPED SEPARATELY IN COORDINATION WITH DMPED, OTHER APPLICABLE DISTRICT AGENCIES, THE ANC AND OTHER COMMUNITY STAKEHOLDERS"

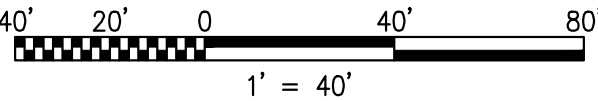

GENERAL NOTE:

1. REFER TO LANDSCAPE DRAWINGS FOR GREEN ROOF DETAILS.
2. REFER TO ARCHITECTURAL DRAWINGS FOR WATERPROOFING.
3. REFER TO LANDSCAPE DRAWINGS FOR GREEN ROOF MAINTENANCE NOTES.
4. REFER TO LANDSCAPE DRAWINGS FOR BIORETENTION DETAILS.
5. REFER TO LANDSCAPE DRAWINGS FOR PLANT SPECIES AND PLANTING GUIDELINES.
6. REFER TO LANDSCAPE DRAWINGS FOR TREE SOIL VOLUMES AND DETAILS.

NOTE:

"NO PERMITTED STORM WATER BMP IS COMPLETE UNTIL FINAL INSPECTION HAS BEEN CONDUCTED AND AN AS-BUILT PLAN HAS BEEN SUBMITTED TO THE DOEE WITHIN 21 DAYS AFTER FINAL INSPECTION FOR REVIEW AND APPROVAL."

GREEN ROOF NOTE:

FERTILIZER IS NOT RECOMMENDED. IF APPLIED, THE FERTILIZER MUST BE A SLOW RELEASE TYPE, RATHER THAN LIQUID OR GASEOUS FORM.

BIORETENTION (ALONG STREET)

STANDARD BIORETENTION DETAIL
(NOT TO SCALE)

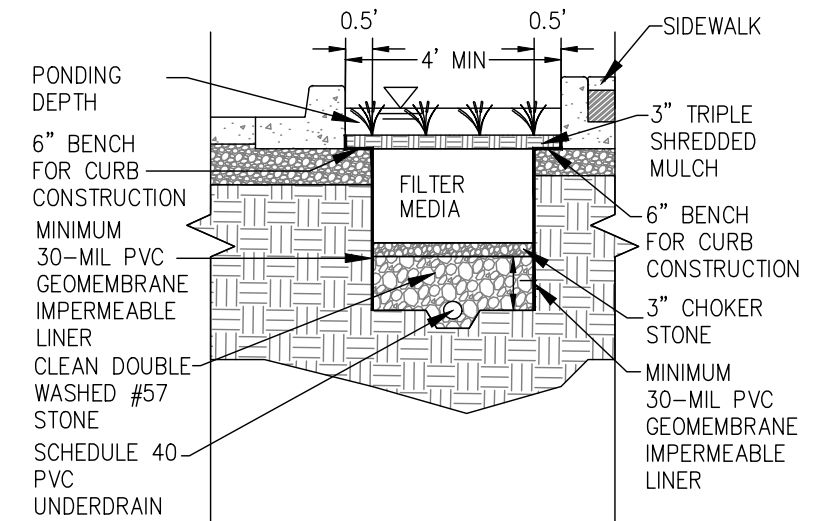

PERMEABLE PAVERS

STANDARD PERMEABLE PAVEMENT DETAIL
(NOT TO SCALE)

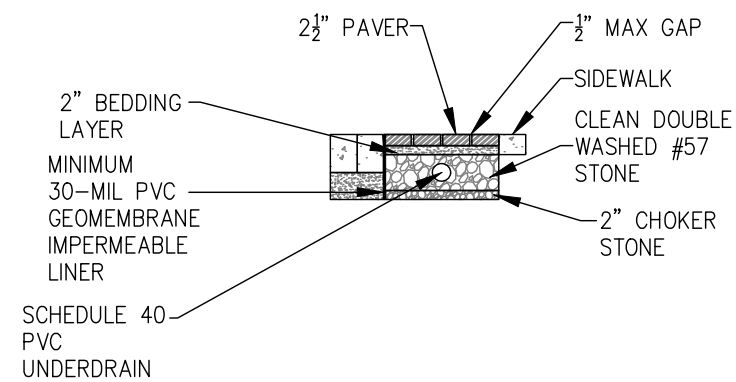

GREEN ROOF

GREEN ROOF DETAIL
(NOT TO SCALE)

